

# INOX | Dual temperature drawers

DUAL TEMPERATURE ▶ GN1/1 ▶ REFRIGERATED DRAWERS

## DWT 122

- 
- 
- GAS R290**
- 
- 4** CLIMATIC CLASS
- 
- GN 1/1**
- 

### DETAILS



Wheels for easy positioning



Main switch and digital thermostat fitted as standard



Sliding engine easy to pull out for manageable after sales servicing



Easily access for clean condenser filter



Evaporator with anti-corrosion treatment



Removable Gasket



### GENERAL FEATURES

- Double drawers switchable cooling/freezer (N.6 GN1/1 Pans)
- Dual temperature model (Easily switchable between cooler and freezer)
- Stainless Steel exterior and interior
- Ventilated Cooling
- Automatic defrost with electric heater
- Evaporator with anti-corrosion treatment
- Foaming Agent Cyclopentane (45mm per side)
- Digital Thermostat
- Sliding engine room for a manageable after sales servicing
- Easy removable condenser filter
- Front panel tilted holes for better air circulation
- Sliding drawers GN1/1 suitable for pans 150mm depth
- Removable Gasket
- N.4 Castor (N.2 in the front with brake)
- Energy efficiency class: -

### PRODUCT DIMENSIONS

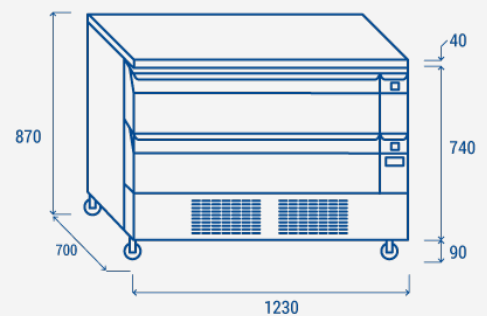

### TECHNICAL SPECIFICATIONS

Capacity	265 L
Temperature	-2°--8°C/-21°--18°C
Consumption	5.2/13.6 kWh/24h
Rated Power	689 W
Noise level	42 dB(A)
Net Weight	155 Kg
Gross Weight	180 Kg
External Dimensions (WxDxH mm)	1230x700x870
Internal Dimensions (WxDxH mm)	951x520x150
Packaging dimensions (WxDxH mm)	1270x740x945
Loading quantities 20'/40'/40'HQ	26/54/54

### CERTIFICATION

CE RoHS

